

TECHNICAL DATASHEET



EF COUPLER

04 Update - 04/2024

TECHNICAL DATA

Article No	001 115 2160 0450
d (mm)	450
D (mm)	520
Z (mm)	320
m (mm)	75
Weight (Kg)	14,070
Box Quantity (pcs)	1
Box Dimension (cm)	53,5X53,5X35

INJECTION MOULDED

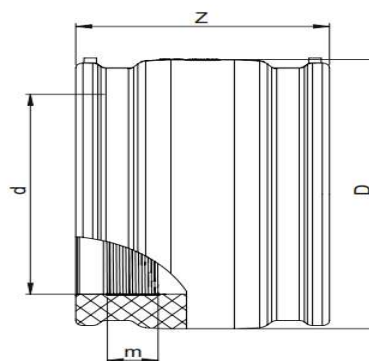

IDENTIFICATION OF PRODUCT

D(mm)	450
SDR	17
RAW MATERIAL	PE 100
PRESSURE CLASS	10 Bar Water 6 Bar Gas
TRADEMARK	NTG
EXECUTION	Injection Moulded
STANDARD	EN 12201-3 EN 1555-3 AS / NZS 4129
SPECIFICATION	Suitable for SDR17...26 pipe 4 mm pin connectors Bifilar welding zone

EF SPECIFICATION

WELDING VOLTAGE	40 V
RESISTANCE	0,560 Ω
WELDING TIME	1920 Sec.
COOLING TIME	30 Min.
WINDING TYPE	Bifilar
WELDING BARCODE	

Tolerance on diameters and thickness according to the standards. The other dimensions are specialized. Tolerance $\pm 5\%$. NTG PLASTIK reserves all the right to change any information without giving prior notice. The production, distribution and utilization of this document without explicit authorization is prohibited.